

186 - GR OURO VERDE

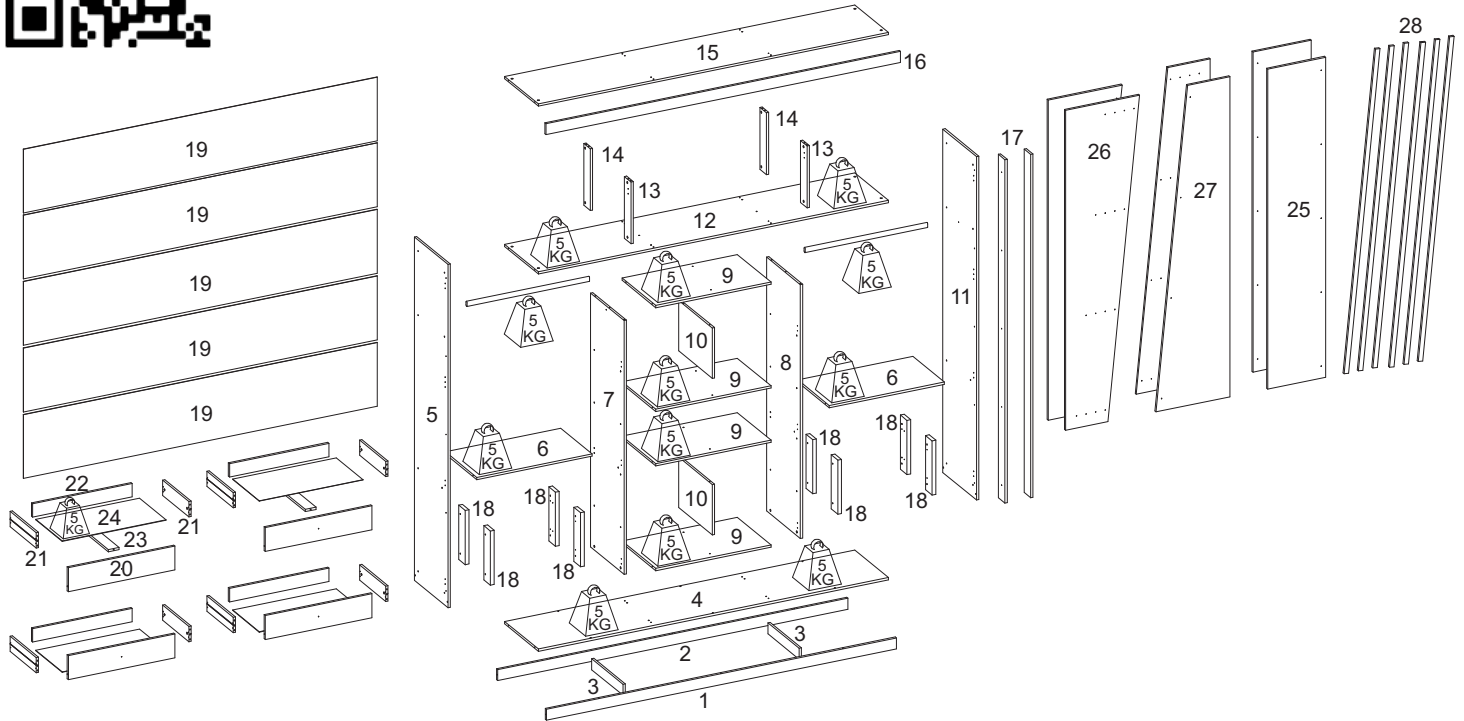



LISTA DE PEÇAS / PIECES LIST / LISTA DE PIEZAS

| SEQ. | REF. | DESCRIÇÃO | DESCRIPTION | DESCRIPCIÓN | MAT.PRIMA | COMP. | LARG. | ESP. | QTD. |
|------|--------|--------------------|-----------------|--------------------------|-----------|-------|-------|------|------|
| 1 | 331885 | Rodapé frontal | Front plinth | Zócalo delantero | MDP | 2340 | 72 | 15 | 1 |
| 2 | 331886 | Rodapé traseiro | Rear plinth | Zócalo trasero | MDP | 2340 | 72 | 15 | 1 |
| 3 | 331887 | Trava rodapé | Plinth lock | Cierre del zócalo | MDP | 418 | 72 | 15 | 2 |
| 4 | 331888 | Base | Base | Zócalo | MDP | 2340 | 450 | 15 | 1 |
| 5 | 331889 | Lateral esquerda | Left side | Lado izquierdo | MDP | 2250 | 450 | 15 | 1 |
| 6 | 331890 | Tampo gaveteiro | Drawer top | Parte superior del cajón | MDP | 770 | 420 | 15 | 2 |
| 7 | 331891 | Divisória esquerda | Left partition | Divisoria izquierda | MDP | 1663 | 450 | 15 | 1 |
| 8 | 331892 | Divisória direita | Right partition | Divisoria derecha | MDP | 1663 | 450 | 15 | 1 |
| 9 | 331893 | Prateleira nicho | Niche shelf | Estante nicho | MDP | 770 | 450 | 15 | 4 |
| 10 | 331894 | Divisória nicho | Niche divider | Separador nicho | MDP | 450 | 330 | 15 | 2 |
| 11 | 331895 | Lateral direita | Right side | Lateral derecho | MDP | 2250 | 450 | 15 | 1 |
| 12 | 331896 | Base maleiro | Trunk base | Base del maletero | MDP | 2340 | 450 | 15 | 1 |
| 13 | 331897 | Batente frontal | Front stop | Tope delantero | MDP | 405 | 88 | 15 | 2 |
| 14 | 331898 | Batente traseiro | Rear stop | Tope trasero | MDP | 405 | 88 | 15 | 2 |
| 15 | 331899 | Chapéu | Hat | Sombrero | MDP | 2340 | 450 | 15 | 1 |
| 16 | 331900 | Vista superior | Top view | Vista superior | MDP | 2370 | 72 | 15 | 1 |
| 17 | 331901 | Vista lateral | Side view | Vista lateral | MDP | 2250 | 88 | 15 | 2 |
| 18 | 331902 | Batente da gaveta | Drawer stop | Tope del cajón | MDP | 355 | 88 | 25 | 8 |
| 19 | 331903 | Fundo | Bottom | Parte inferior | HDF | 2364 | 418 | 3 | 5 |
| 20 | 331904 | Frente de gaveta | Drawer front | Frente del cajón | MDP | 712 | 157 | 15 | 4 |
| 21 | 331905 | Lateral de gaveta | Drawer sides | Laterales del cajón | MDP | 350 | 100 | 15 | 8 |
| 22 | 331906 | Contra fundo | Back | Parte trasera | MDP | 665 | 88 | 15 | 4 |
| 23 | 331907 | Apoio de gaveta | Drawer support | Soporte del cajón | MDP | 350 | 72 | 15 | 4 |
| 24 | 331908 | Fundo da gaveta | Drawer bottom | Fondo del cajón | HDF | 693 | 355 | 3 | 4 |
| 25 | 331909 | Porta central | Central door | Puerta central | MDP | 2097 | 388 | 15 | 2 |
| 26 | 331910 | Porta lateral | Side doors | Puerta lateral | MDP | 2097 | 494 | 15 | 2 |
| 27 | 331911 | Porta | Door | Puerta | MDP | 2097 | 494 | 15 | 2 |
| 28 | 331912 | Ripado | Slatted | Lamas | MDP | 2096 | 30 | 15 | 6 |

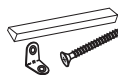
INSTRUÇÃO MONTAGEM PRODUTO
 Intructions to Assembly / Instrucciones de montaje

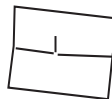
 **Separe as peças e acessórios de maneira organizada**
 Separate parts and accessories in way organized
 Separe las piezas y accesorios de manera organizada

 **Forrar o chão com o papelão das embalagens.**
 Cover the floor with the cardboard
 Cubra el suelo con la embalaje de cartón

 **É necessário 02 pessoa para montar o produto**
 02 people are required to assemble the product
 Se requieren 02 persona para ensamblar el producto

O produto deve ser a montado por um profissional qualificado
 The product must be assembly by a professional
 El producto debe ser ensamblado por un profesional calificado

Ferramentas necessárias (não fornecidas)

Not include tools / No herramientas



CUIDADO PARA CONSERVAÇÃO E LIMPEZA DO MÓVEL
 Care to conservation and clean / Cuidados de limpieza

Peso máximo de carga informado refere-se a objetos distribuido de maneira uniforme sobre toda área de contato da peça



The maximum load weight informed refers to objects distributed evenly over the entire contact area of the part
 Conjunto de carga máxima de peso se refiere a objetos distribuidos uniformemente sobre toda el área de contacto de la pieza de trabajo.



Não molhar o móvel e não expor em lugar úmido
 Do not wet the mobile and do not expose in a wet place
 No moje el producto y no exponer en un lugar húmedo



Não expor o móvel próximo de fontes de calor.
 Do not expose the mobile near heat sources
 no exponga cercano de fuentes de calor



Não usar produtos abrasivos.
 Do not use abrasive products.
 No utilice productos abrasivos.



Limpe com flanela limpa e seca.
 Clean with dry cloth
 Limpieza con un paño limpio y seco

LISTA DE ACESSÓRIOS E FERRAGENS / ACCESSORIES AND HARDWARE / ACCESORIOS Y HARDWARE



A - 700137- Parafuso 4,5x45 (56x)
 screw / tornillo



B- 700136 - Parafuso 4,5x35 (16x)
 screw / tornillo



C- 701352 - Parafuso 3,5x30 (16x)
 screw / tornillo



D - 700124-Parafuso 3,5x25 (83x)
 screw / tornillo



E - 700129-Parafuso 4,0x14 (144x)
 screw / tornillo



F - 700121-Parafuso 3,5x12 (158x)
 screw / tornillo



G- 700146-Parafuso minifix (20x)
 Minifix screw /
 Tornillo minifix



H- 700148-Tambor Minifix (20x)
 Minifix Drum / Tambor minifix



I - 700113-Corrediça (4x)
 runners / corredera



J - 700539-Cantoneira (8x)
 corner / esquina



K- 700542-Cavilha 6x30 (36x)
 peg / cerrojo



L- 700446 - Porca cilíndrica (12x)
 Cylindrical Nut / Tuerca cilíndrica



M - 700438 - Suporte cabide (4X)
 hook support / soporte gancho



N - 702986 - Cabideiro Alumínio (2x)
 Coat Rack / Perchero



O- 701333-Dobradiça
 c/ pistão + calço (24x)
 hinge / bisagra



P- 700192-Puxador (4x)
 handle / manija



Q- 703055 - Perfil H (4x)
 Frame / Perfil



R- 700538 - Cantoneira (4x)
 corner / esquina



S - 700433-Suporte angular (7x)
 Angled support / Soporte en ángulo



T- 700157-Prego (158x)
 nail / clavo



U - 700464 - Kit com 8 Pes (1x)
 foot / pie



V- -703054 - Puxador 2096 mm (6x)
 Handle / Manija



W- 700516 - Cola (1x)
 glue / pegamento



Y- 700419-Tapa furo (62x)
 cover / tapa



Z- 700419-Tapa furo (32x)
 cover / tapa

01° PASSO - Fixar peças 3 nas peças 1 e 2

01° STEP - Fix parts 3 to parts 1 and 2

01° PASO - Fijar las partes 3 a las partes 1 y 2

F



J

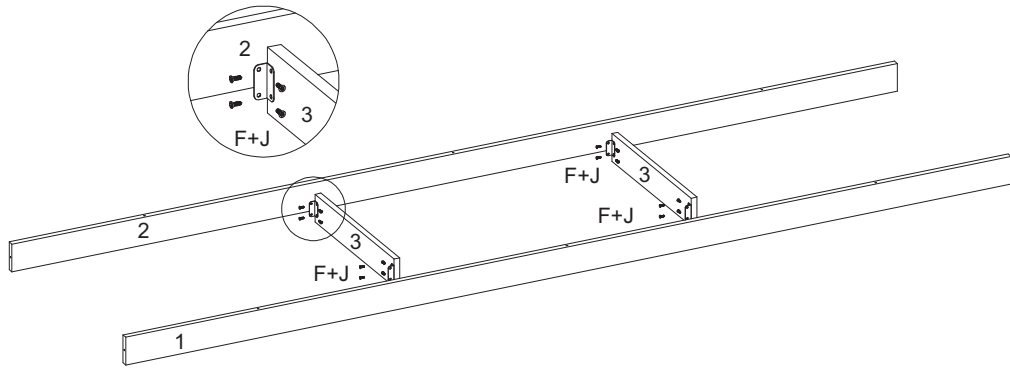

02° PASSO - Fixar acessórios U nas peças 1,2 e 3

02° STEP - Fix U fittings to parts 1,2 and 3

02° PASO - Fijar los racores en U a las piezas 1, 2 y 3

U

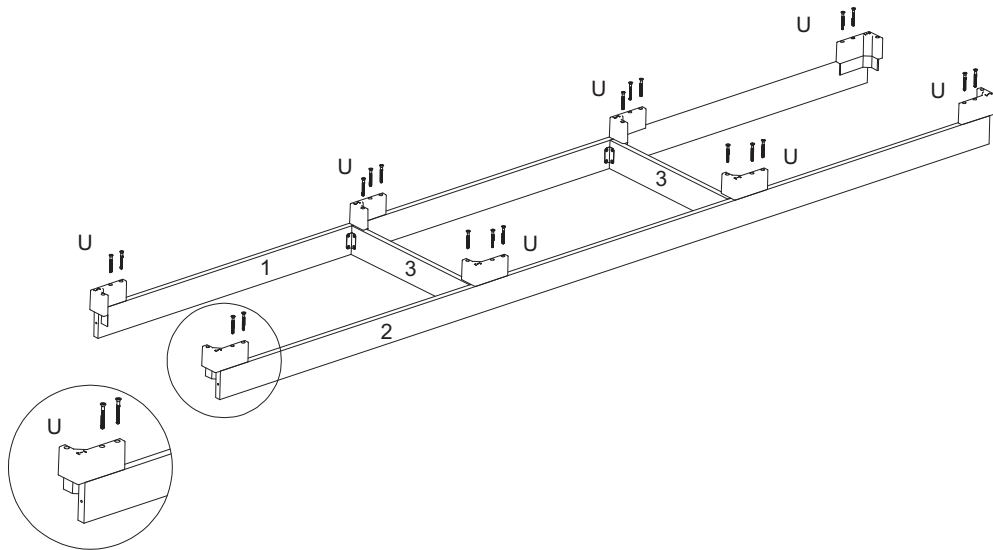

03° PASSO - Fixar peça 4 nas peças 1 e 2

03° STEP - Fix part 4 to parts 1 and 2

03° PASO - Fijar las parte 4 a las partes 1 y 2

A



F



G



J



L

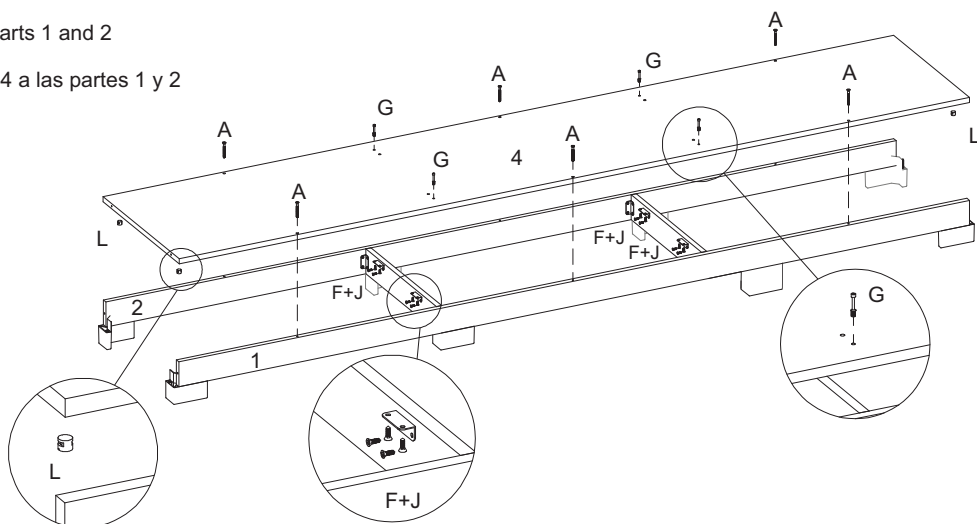

04° PASSO - Fixa peça 5 nas peças 1, 2 e 4

04° STEP - Fix part 5 to parts 1, 2 and 4

04° PASO - Fijar la parte 5 a las partes 1, 2 y 4

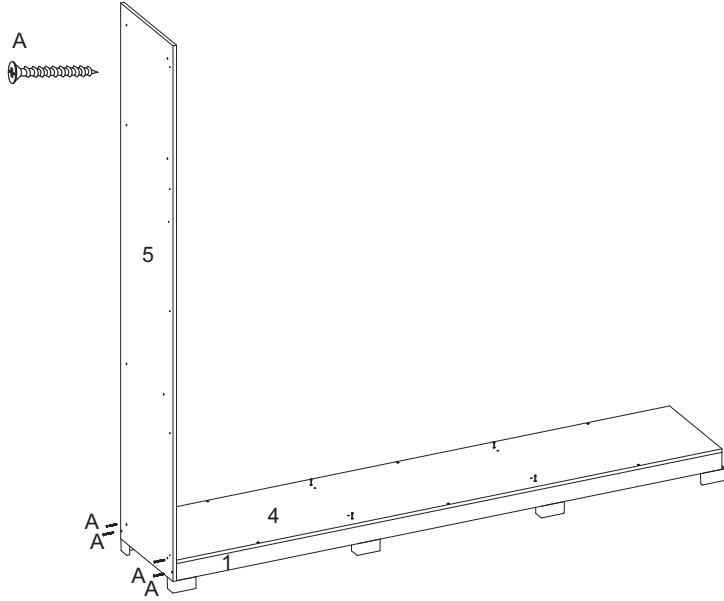

05° PASSO - Fixar peça 7 nas peça 4

05° STEP - Fix part 7 to part 4

05° PASO - Fijar la parte 7 a la parte 4

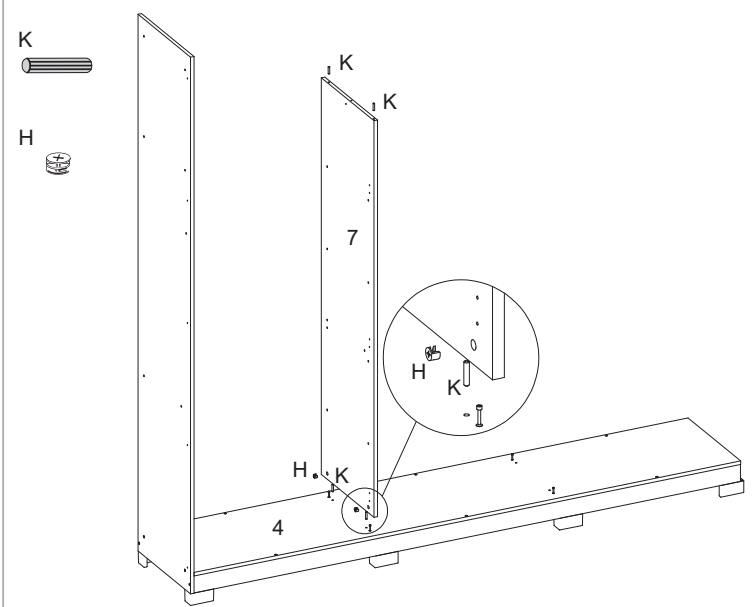

06° PASSO - Fixar peça 6 nas peças 5 e 7

06° STEP - Fix part 6 to parts 5 and 7

06° PASO - Fijar la parte 6 a las partes 5 y 7

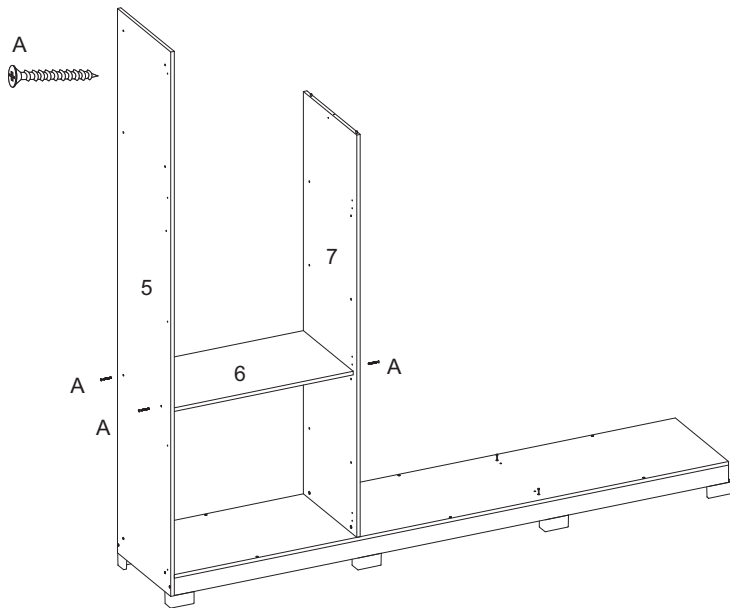

07° PASSO - Fixar peça 8 na peça 4

07° STEP - Fix part 8 to part 4

07° PASO - Fijar la parte 7 a la parte 4

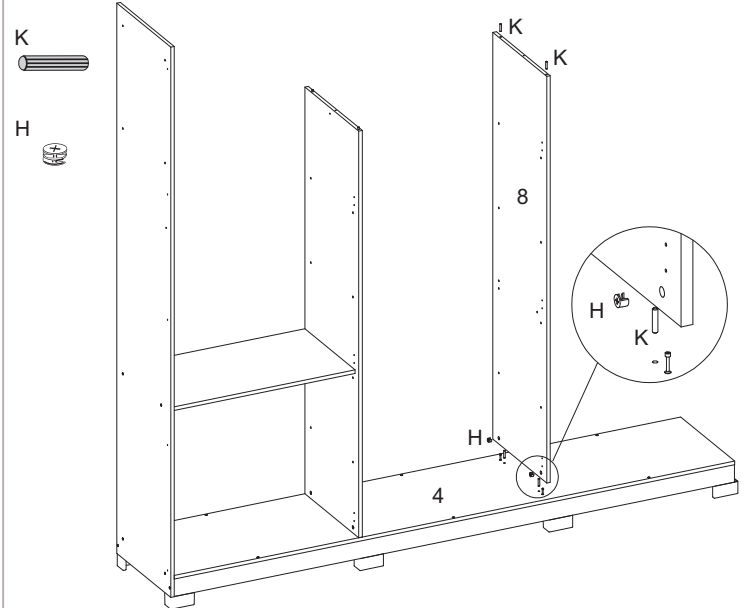

08° PASSO - Fixar peças 9 nas peças 7 e 8

08° STEP - Fix parts 9 to parts 7 and 8

08° PASO - Fijar las piezas 9 a las piezas 7 y 8

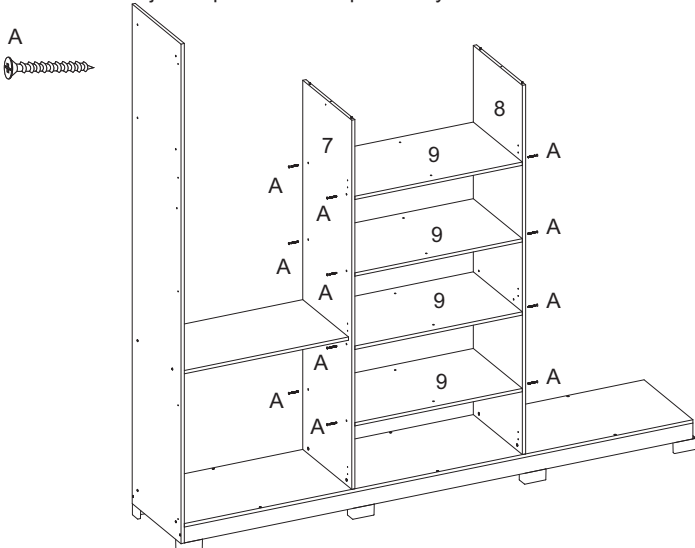

09° PASSO - Fixar peça 11 nas peça 1, 2 e 4

09° STEP - Fix part 11 to parts 1, 2 and 4

09° PASO - Fijar la parte 11 a las partes 1, 2 y 4

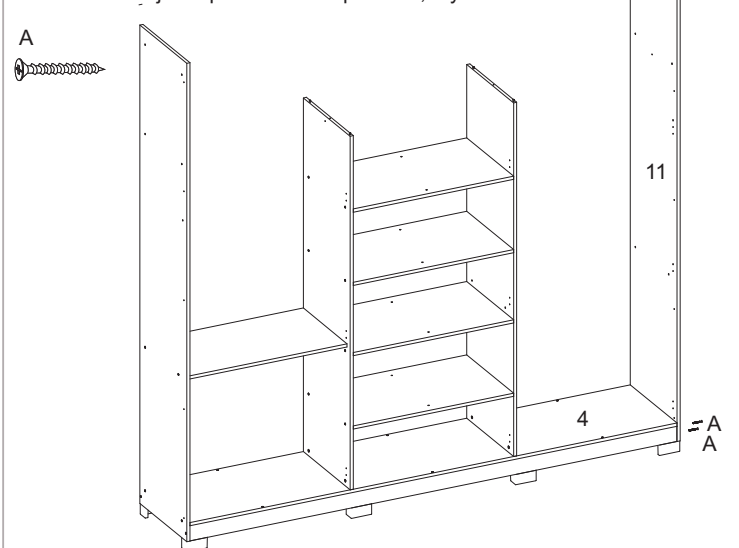

10° PASSO - Fixar peças 6 e 10 nas peças 10 e 11

10° STEP -Fix parts 6 and 10 to parts 10 and 11

10° PASO -Fijar las partes 6 y 10 a las partes 10 y 11

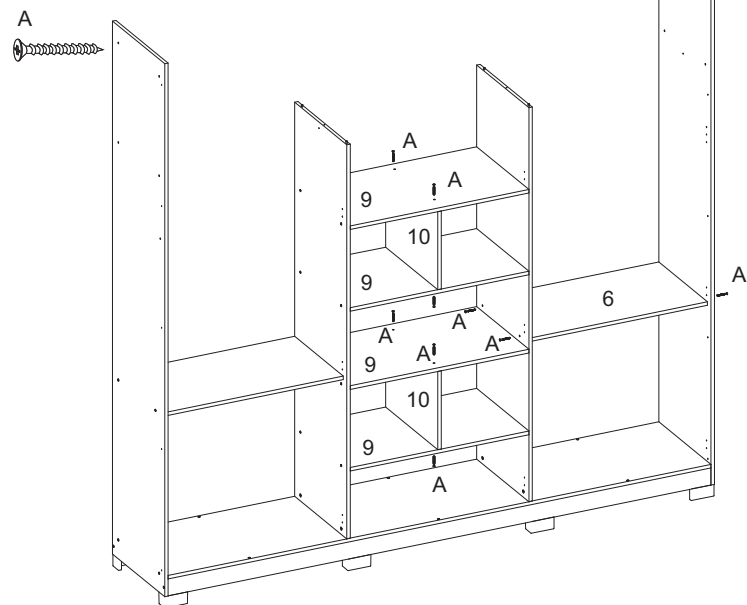

11° PASSO - Fixar peça 10 na peça 4

11° STEP -Fix part 10 to part 4

11° PASO - Fijar la parte 10 con la parte 4

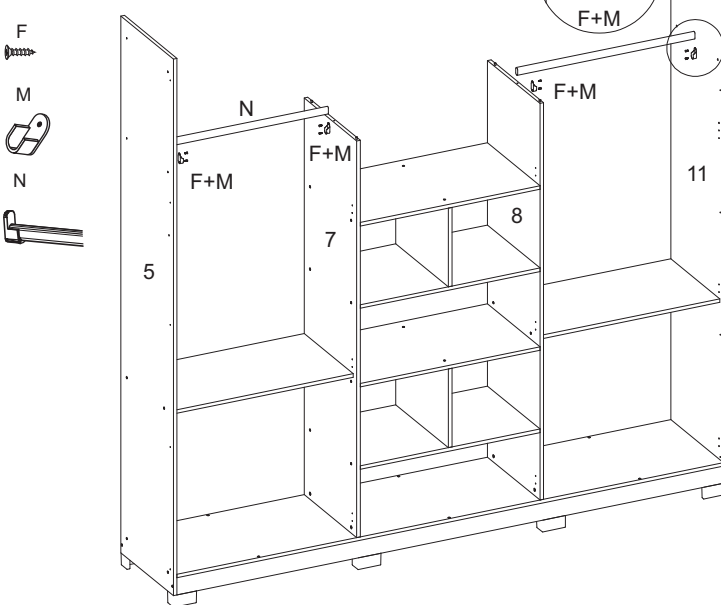

12° PASSO - Fixar peça 12 nas peças 5,7,8 e 11

12° STEP -Fix part 12 to parts 5,7,8 and 11

12° PASO - Fijar la parte 12 a las partes 5,7,8 y 11

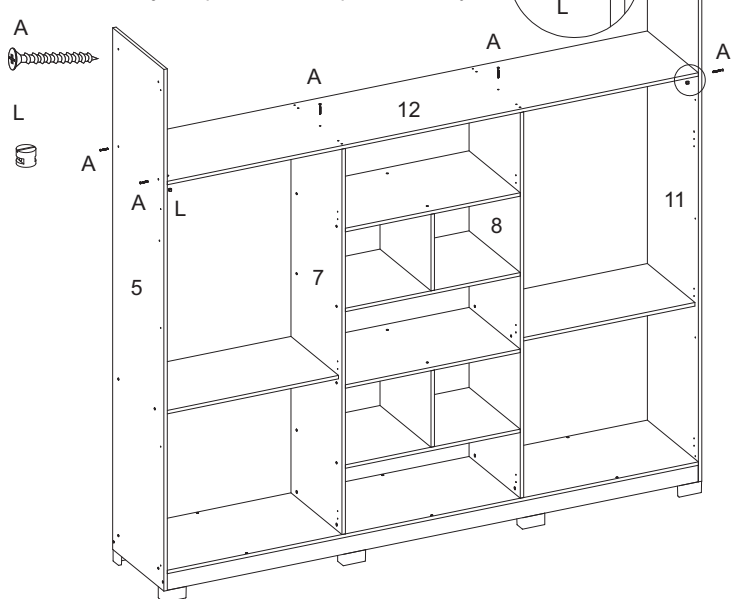

13° PASSO - Fixar peças 13 e 14 na peça 12

13° STEP -Fix parts 13 and 14 to part 12

13° PASO - Fijar las partes 13 y 14 a la parte 12

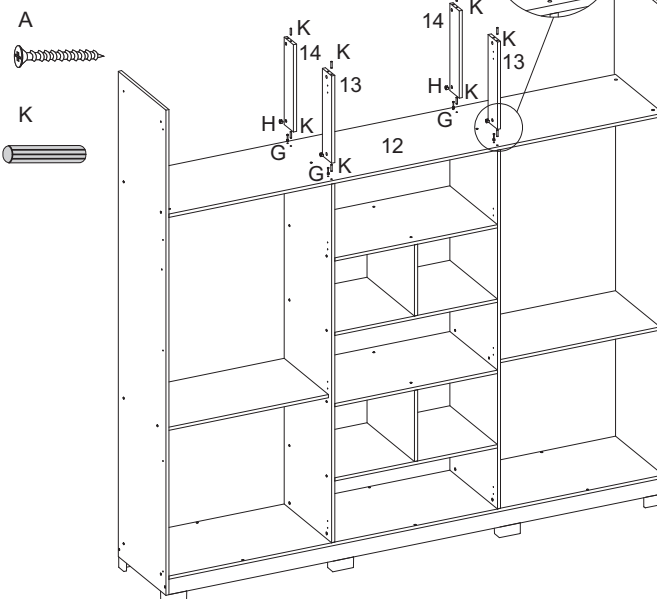

14° PASSO - Fixar peça 15 nas peças 5,11,13 e 14

14° STEP -Fix part 14 to part 5

14° PASO Fijar la parte 15 a las partes 5, 11, 13 y 14

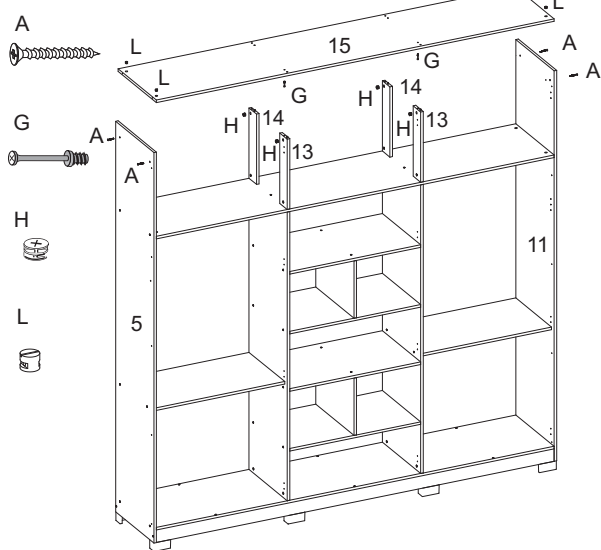

15° PASSO - Fixar peças 17 nas peças 5 e 11

15° STEP -Fix parts 17 to parts 5 and 11

15° PASO - Fijar las piezas 17 a las piezas 5 y 11

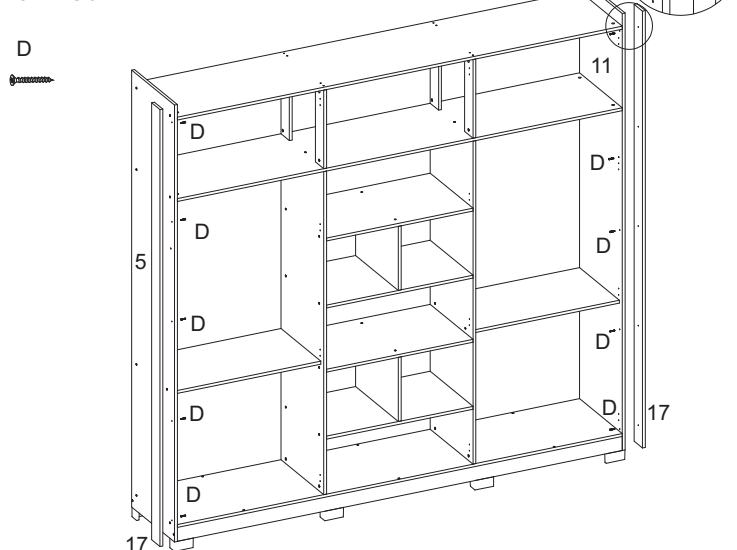

16º PASSO - Fixar peças 11 e 15 nas peças 1,2,5 e 14

16º STEP - Fix parts 11 and 15 to parts 1,2,5 and 14.

16º PASO - Fijar las piezas 11 y 15 a las piezas 1,2,5 y 14.

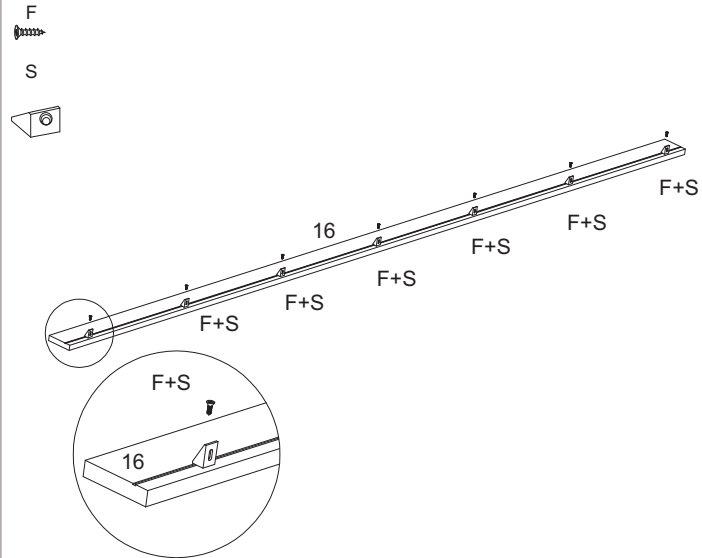

17º PASSO - Fixar peça 16 nas peça 15

17º STEP - Fix part 16 to part 15

17º PASO - Fijar la parte 16 a las parte 15

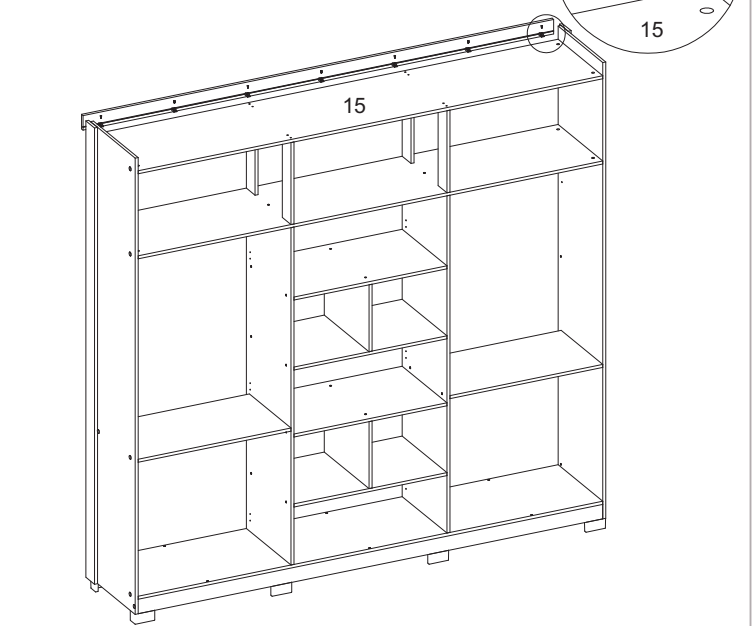

18º PASSO - Fixar peças 19 na parte de trás do produto

18º STEP - Fix parts 19 to the back of the product

18º PASO - Fijar las piezas 19 en la parte posterior del producto

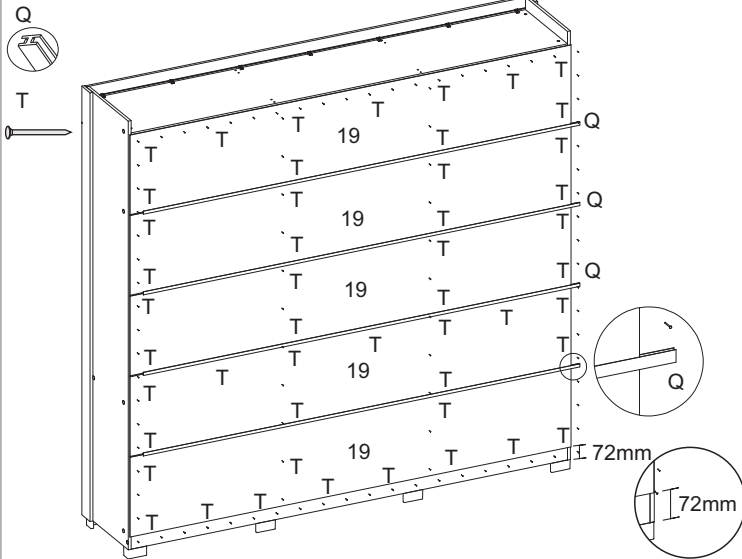

19º PASSO - Fixar acessórios F+I nas peças 18

19º STEP - Fix F+I fittings to parts 18

19º PASO - Fijar accesorios F+I a las piezas 18

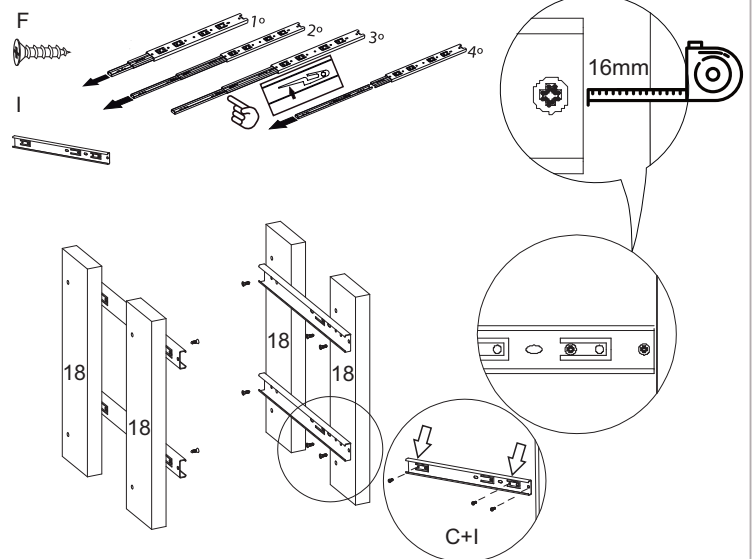

20º PASSO - Fixar peças 18 nas peças 5,7,8 e 11

20º STEP - Attach parts 18 to parts 5,7,8 and 11

20º PASO - Fijar las piezas 18 a las piezas 5,7,8 y 11

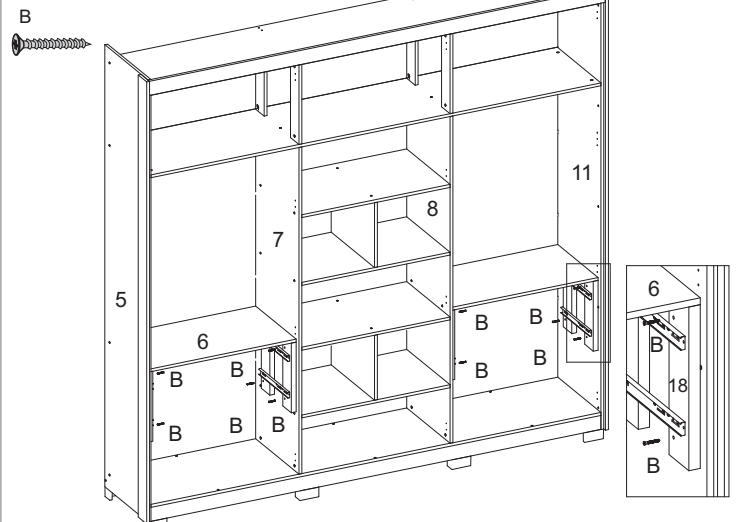

21º PASSO - Fixar peças 21 nas peças 20 e 22

21º STEP - Fix parts 21 to parts 20 and 22

21º PASO - Fijar las piezas 21 a las piezas 20 y 22

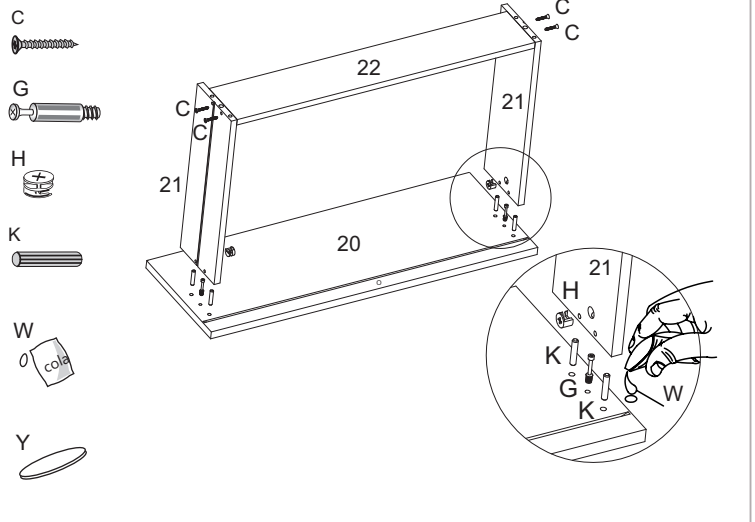

22° PASSO - Fixar peça 24 nas peças 21 e 22

22° STEP - Fix part 24 to parts 21 and 22

22° PASO - Fijar la parte 24 a las partes 21 y 22

F



T

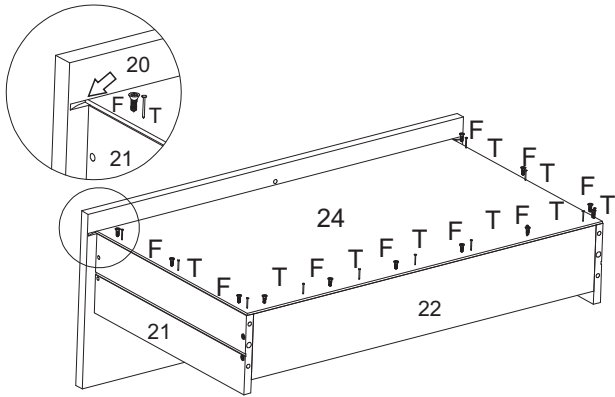

23° PASSO - Fixar peça 23 nas peças 20 e 22

23° STEP - Fix parts 23 to parts 20 and 22

23° PASO - Fijar las piezas 23 con las piezas 20 y 22

D



F



K



R

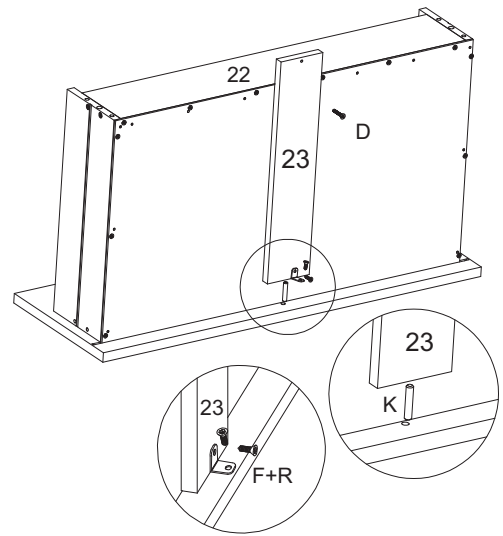

24° PASSO - Fixar acessórios F+I nas peças 21

24° STEP - Fix F+I fittings to parts 21

24° PASO - Fijar los accesorios F+I en las piezas 21

F



I

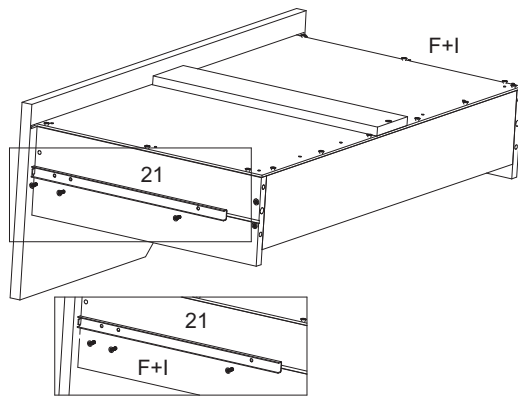

25° PASSO - Fixar acessórios D+P nas peça 20

25° STEP - Fix D+P fittings to parts 20

25° PASO - Fijar los accesorios D+P a la pieza 20

D



P

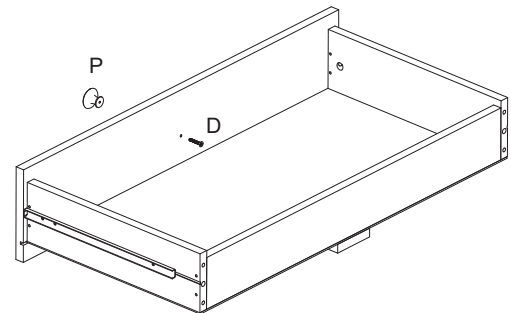

26° PASSO - Encaixar as gavetas no produto

26° STEP - Fitting the drawers into the product

26° PASO - Encajar los cajones en el producto

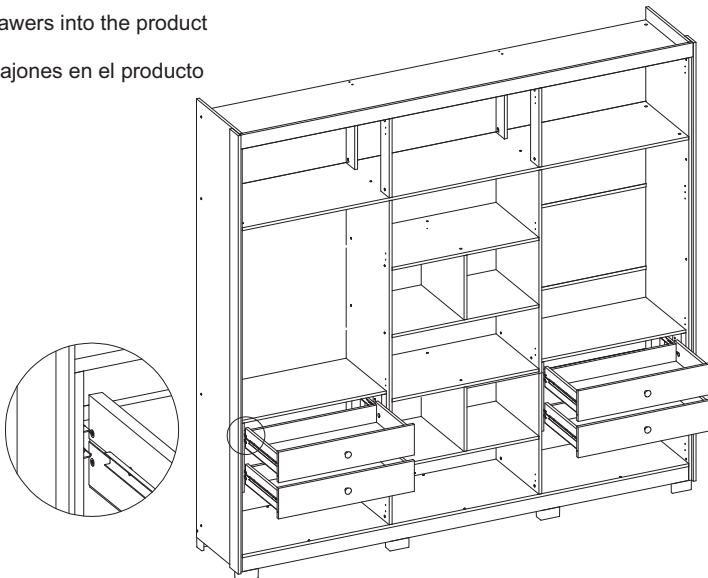

27º PASSO - Fixar os acessórios E+O nas peças 25,26 e 27

27º STEP - Fix accessories to parts 28

27º PASO - Fijar los racores E+O a las piezas 25, 26 y 27

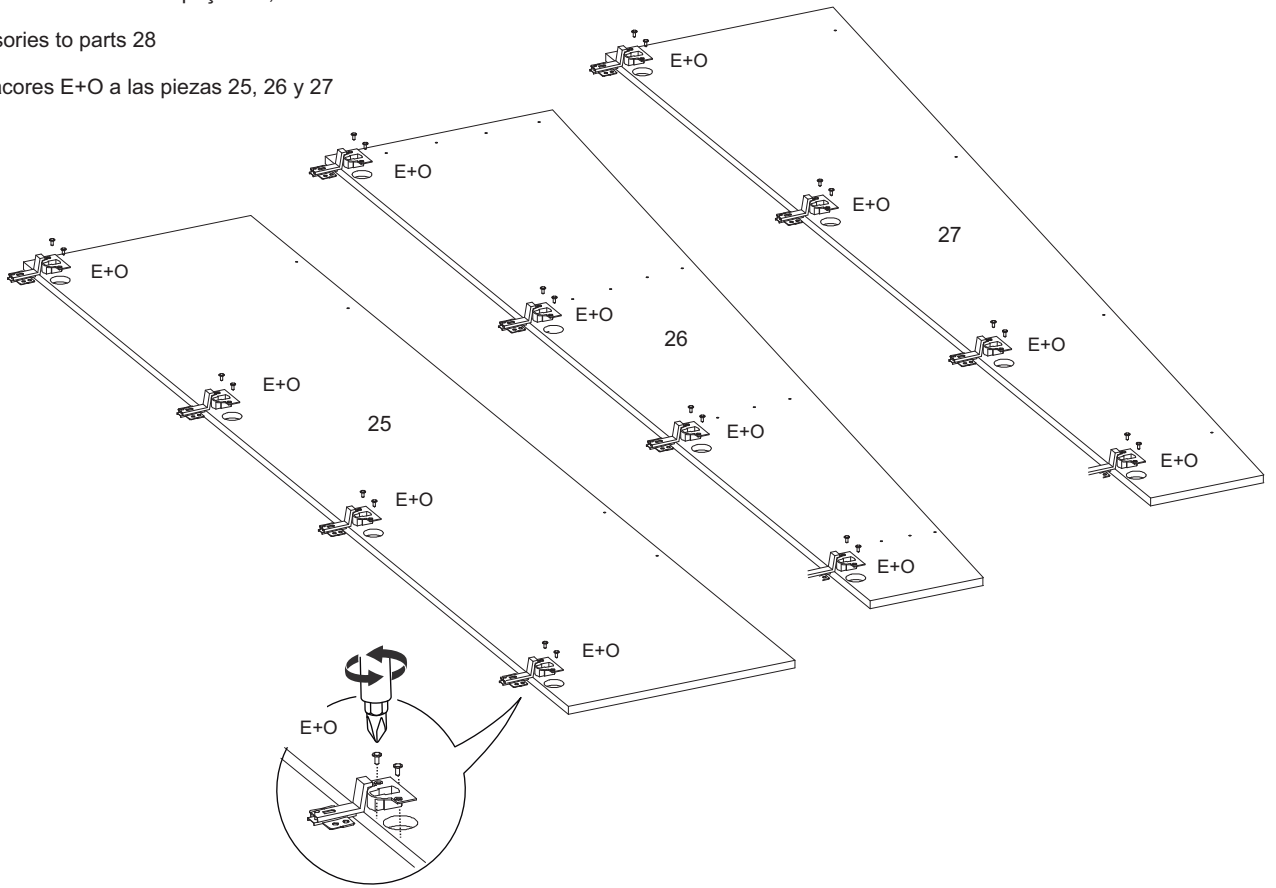
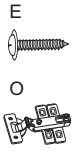

28º PASSO - Fixar peças 25,26 e 27 nas peças 5,7,8 e 11

28º STEP - Fix parts 25,26 and 27 to parts 5,7,8 and 11

28º PASO - Fijar las piezas 25,26 y 27 a las piezas 5,7,8 y 11

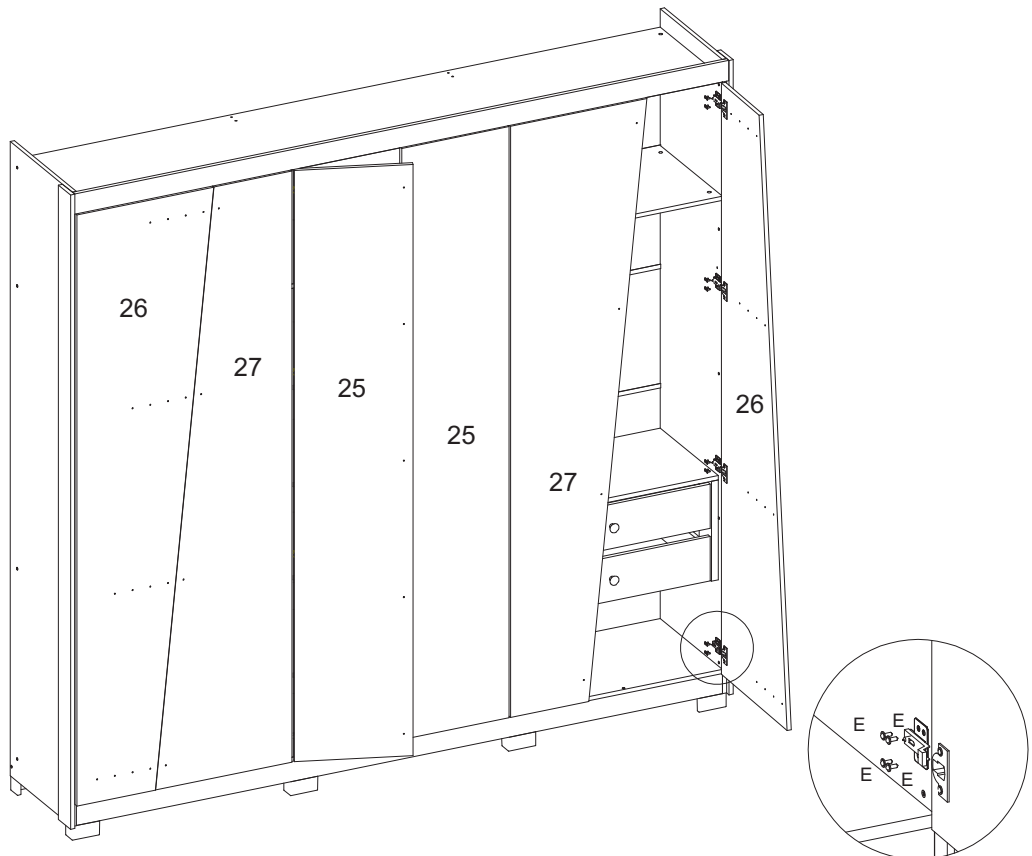

29° PASSO - Fixar peças 28 nas peças 26

29° STEP - Fix parts 28 to parts 26

29° PASO - Fijar las piezas 28 a las piezas 26

D

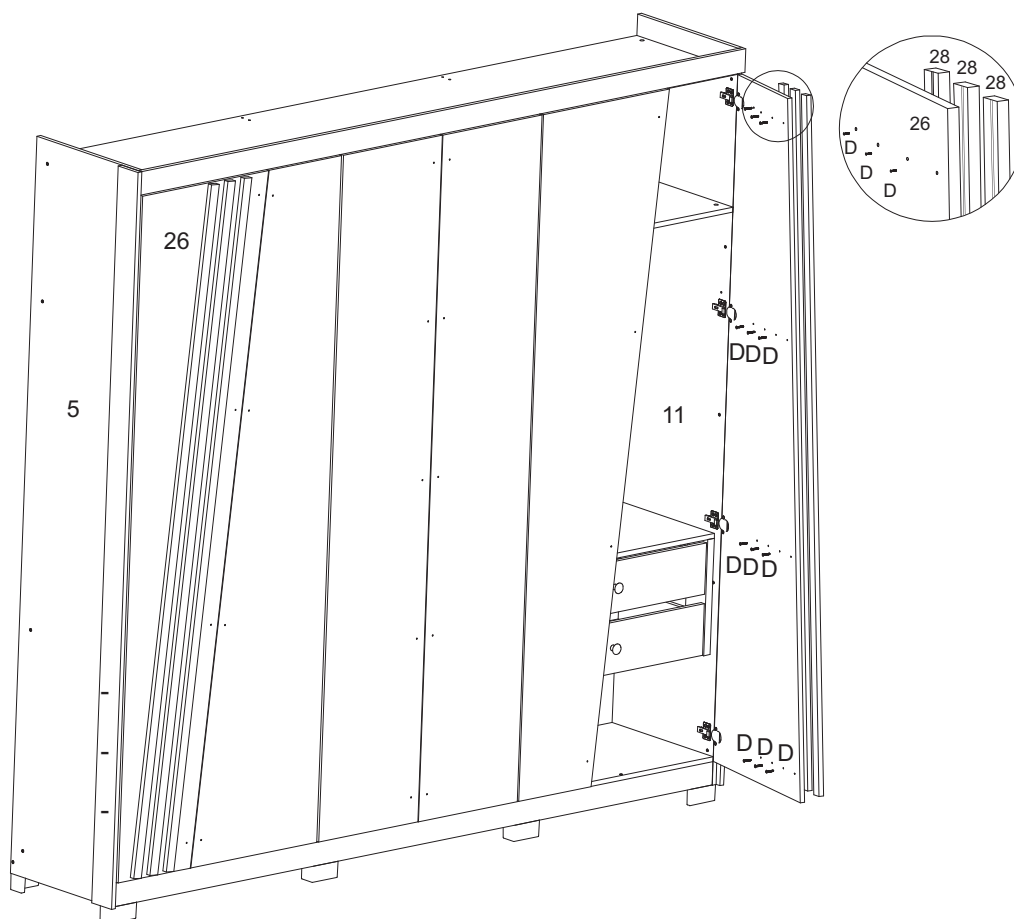

30° PASSO - Fixar acessórios V nas peças 25,26 e 27

30° STEP - Fix V-fittings to parts 25, 26 and 27

30° PASO - Fijar los racores en V a las piezas 25, 26 y 27

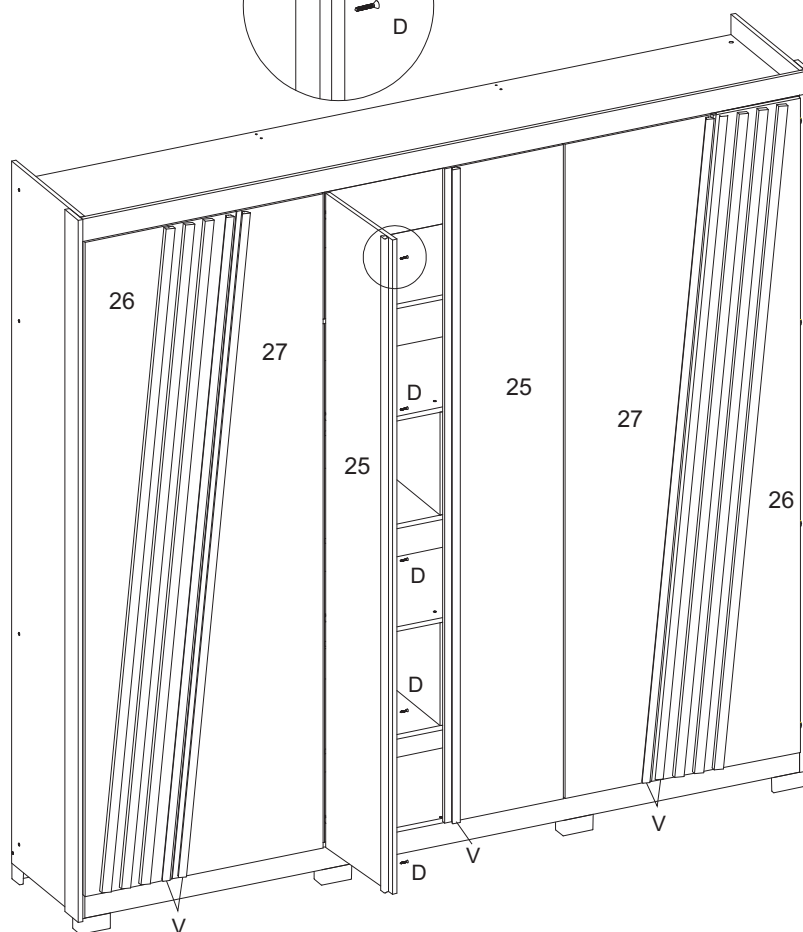
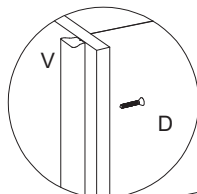

Aspecto final do produto
Aspecto final del producto.
Final appearance of the product

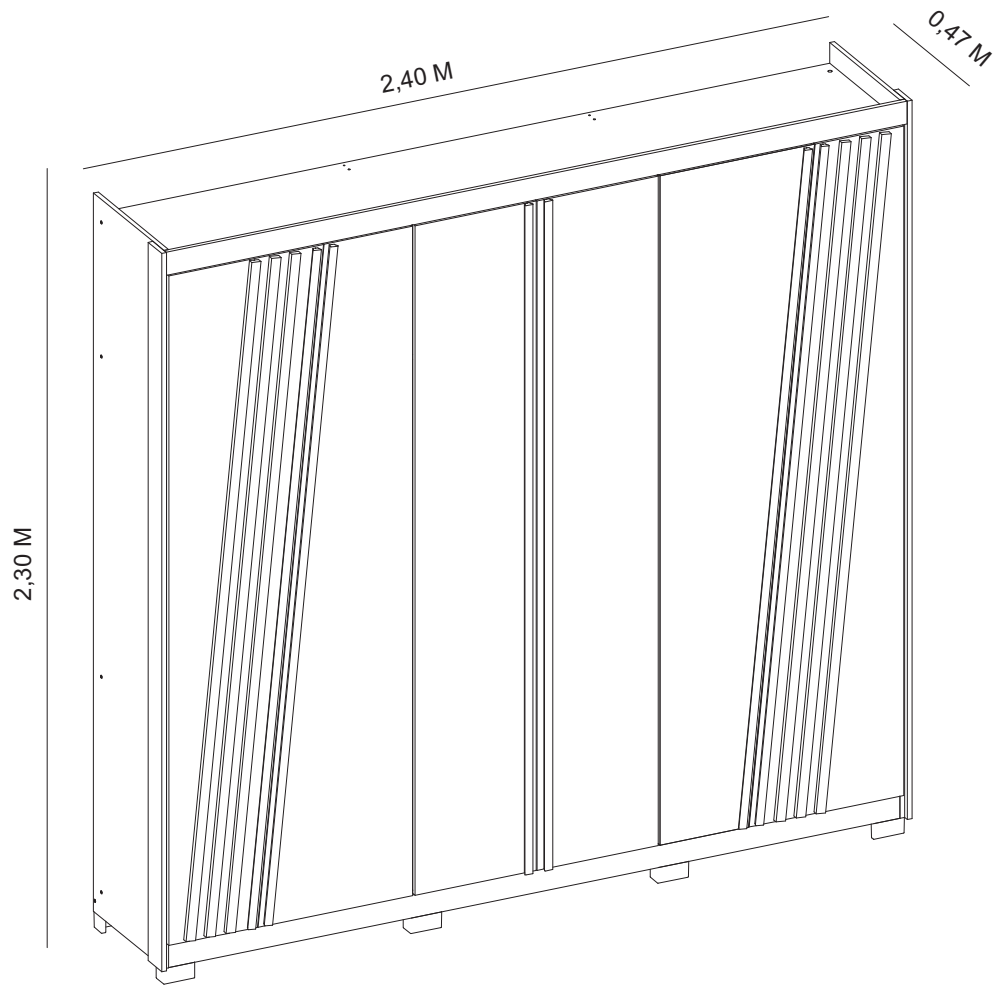

MONTAGEM PARA O PRODUTO QUE CONTEM ESPELHO
ASSEMBLY FOR THE PRODUCT THAT CONTAINS MIRROR
MONTAJE DEL PRODUCTO QUE CONTIENE ESPEJO

